

Installation Instructions

X-Force UTV Lift

(000 Series)

Capacity 2,275 lbs (1,035 kg)

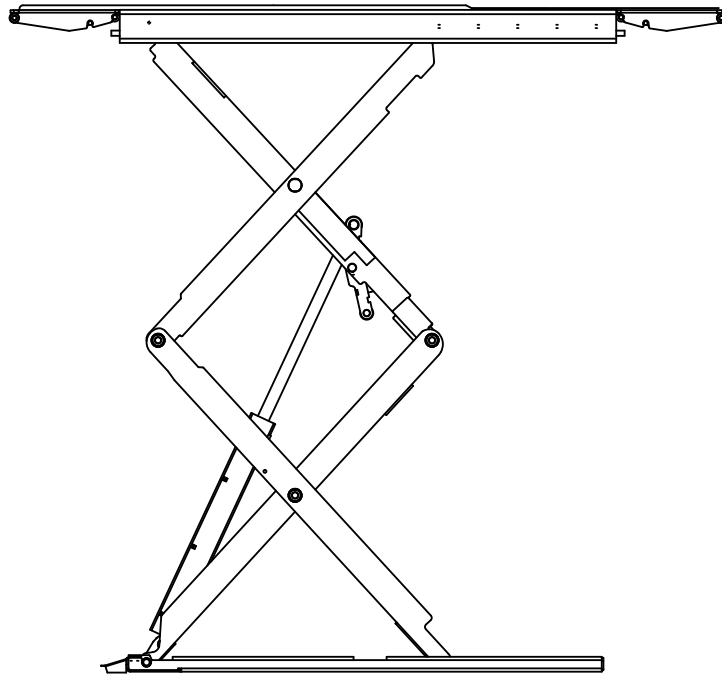

**Read entire manual before assembling, installing,
operating, or servicing this equipment.**

LP20640

1. General Lift Location

Use architect's plan when available to locate lift. Fig. 1 shows typical lift dimensions.

The power unit may be placed on the left or right.

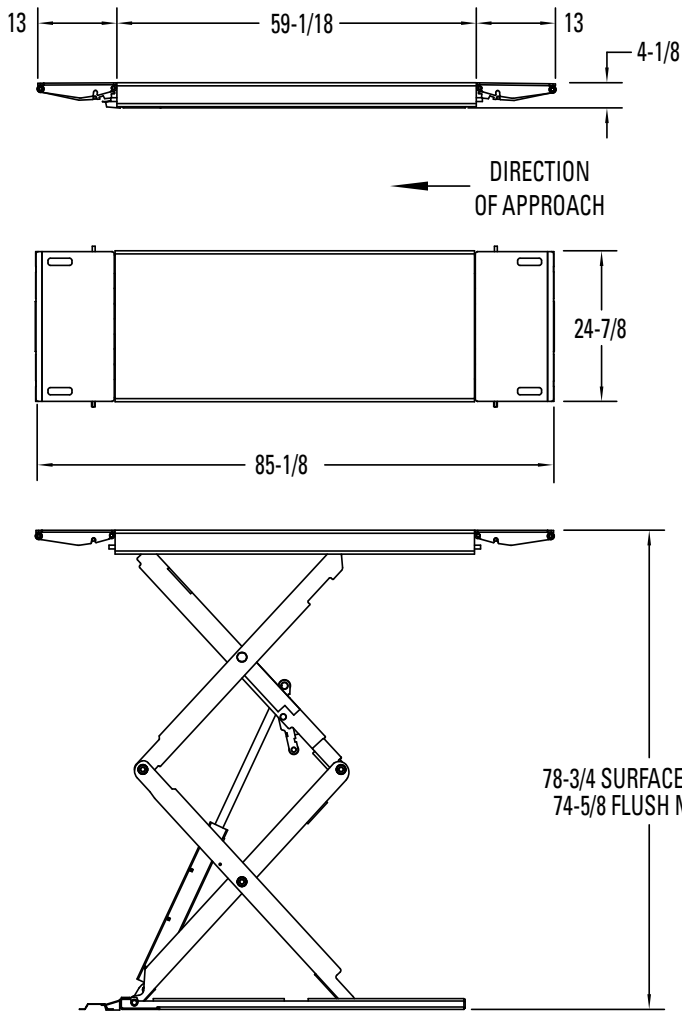

SPECIFICATION	SURFACE MOUNT
COLLAPSED HEIGHT	4-1/8
RAISED HEIGHT	78-3/4
OVERALL LENGTH	85-1/8
PLATFORM LENGTH	59-1/8
RAMP LENGTH	13
OVERALL WIDTH	24-7/8
CAPACITY AT 180 MM HEIGHT	2275 lbs
LIFTING TIME	43 SEC.
1Ø MOTOR	60 HZ, 115V

Fig. 1

2. Vertical Clearance

Check the height of the area where the lift is to be installed. Clearance should be calculated based on the full raised height of the lift and the height of the tallest vehicle being lifted.

⚠️ WARNING Failure by purchaser to provide adequate clearance could result in unsatisfactory lift performance, property damage, or personal injury.

3. Flooring

Be certain you have the proper concrete floor to properly handle the loaded lift. Floor should be in generally good condition with no large cracks, spalling or deterioration.

Minimum requirements for concrete are 4 inches minimum depth, with steel reinforcement, cured to 3000 psi. Floor should be level within 1/4 inch under each platform area. No anchors should be installed within 2-1/2 inches of any crack, edge, or expansion joint. There should be no floor seam under ramp roller locations. If these conditions cannot be met, a pad may be poured to accommodate the lift.

Check with local building inspectors and/or permits office for any special instructions or approvals required for your installation.

⚠️ WARNING Failure by purchaser to provide the recommended mounting surface could result in unsatisfactory lift performance, property damage, or personal injury.

4. Electrical Requirements from Customer

- 115 VAC single phase 60 Hz power for 15 full load amps.
- All wiring must conform to all national and local electrical codes.

IMPORTANT Use separate circuit for each power unit. Protect each circuit with a time delay fuse or circuit breaker.

⚠️ WARNING Make sure that the main power supply is disconnected to avoid the possibility of electrocution.

5. Safety Notices and Decals

For your safety, and the safety of others, read and understand all of the safety notices and decals included here.

Proper maintenance and inspection is necessary for safe operation.

DO NOT operate a damaged lift.

Safety decals similar to those shown here are found on a properly installed lift. Be sure all safety decals have been placed on the control cabinet. Verify that all authorized operators know the location of these decals and fully understand their meaning. Replace worn, faded, or damaged decals promptly.



⚠️ WARNING Do not attempt to raise a vehicle on the lift until the lift has been correctly installed and adjusted as described in this manual.

SAFETY WARNING LABELS FOR HINGED FRAME ENGAGING LIFTS

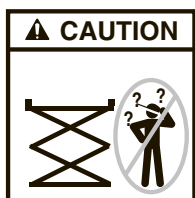

Lift Owner/User Responsibilities:

- A. This Safety Warning placard **SHALL** be displayed in a conspicuous location in the lift area.
- B. Use one of the mounting arrangements illustrated on back of this placard.
- C. These Safety Warning labels supplement other documents supplied with the lift.
- D. Be certain all lift operators read and understand these labels, operating instructions and other safety related information supplied with the lift.

 <p>WARNING</p> <p>Position vehicle with center of gravity midway between adapters.</p>	 <p>WARNING</p> <p>Remain clear of lift when raising or lowering vehicle.</p>	 <p>WARNING</p> <p>Keep feet clear of lift while lowering.</p>
 <p>WARNING</p> <p>Clear area if vehicle is in danger of falling.</p>	 <p>WARNING</p> <p>Avoid excessive rocking of vehicle while on lift.</p>	 <p>WARNING</p> <p>Keep clear of pinch points when lift is moving.</p>

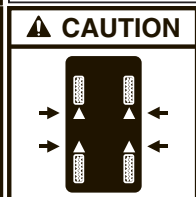
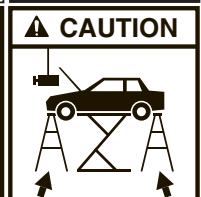
 <p>CAUTION</p> <p>Lift to be used by trained operator only.</p>	<p>Power Unit: Secure placard near lift controls.</p>  <p>Lift Control Console: Secure placard in an accessible location.</p>  <p>The messages and pictographs shown are generic in nature and are meant to generally represent hazards common to all automotive lifts regardless of specific style.</p> <p>Funding for the development and validation of these labels was provided by the Automotive Lift Institute, PO Box 1519 New York, NY, 10101-1519.</p> <p>They are protected by copyright. Set of labels may be obtained from ALI or its member companies.</p> <p>© 1992 by ALI, Inc. ALIWL300csw</p>	
---	---	--

 <p>CAUTION</p> <p>Authorized personnel only in lift area.</p>	 <p>CAUTION</p> <p>Use vehicle manufacturer's lift points.</p>	 <p>CAUTION</p> <p>Always use safety stands when removing or installing heavy components.</p>
--	--	---

 <p>SAFETY INSTRUCTIONS</p> <p>Read operating and safety manuals before using lift.</p>	 <p>SAFETY INSTRUCTIONS</p> <p>Proper maintenance and inspection is necessary for safe operation.</p>	 <p>SAFETY INSTRUCTIONS</p> <p>Do not operate a damaged lift.</p>
---	---	---

6. Installation

Important: Always wear safety glasses while installing lift.

Required Tools and Supplies List

1. 115, 60 Hz, 20 amp service
2. 15 liters of ATF Dexron III or hydraulic fluid that meets ISO 32 specifications
3. Chalk line
4. Tape measure, 15 ft min.
5. Level, 6 ft min.
6. Open end wrenches
7. Needle nose pliers
8. Cross head screw driver
9. Oil funnel
10. Hammer drill with 1/2" carbide drill bit

7. Power Unit Layout

1. Layout the service bay according to the architect's plans or owners instructions. Failure to install in this orientation can result in personal and property damage. Be certain that the proper conditions exists, see previous page.

Note: The correct orientation of the platform is critical for proper layout of the lift.

2. Place the power unit in the approximate location (do not anchor), Fig. 2. Hydraulic hoses should be 1/4" min. ID with a min. working pressure of 4000 psi with #6 JIC Swivel Female fittings. Extension Hose Kits available.

8. Platform and Power Unit Detail Layout

1. Place platform and power unit as shown in Fig. 2. **DO NOT anchor any components at this time.** The power unit should be located on the opposite end of vehicle approach, as shown in Fig. 2. Operator should be in a position to notice any misalignment of lifting pads during operation. Rotary Lift does not recommend placing the power unit in a different location orientation and doing so would be the responsibility of the installer and/or end user.

IMPORTANT Power unit should always be oriented so operator is facing the direction of the lift when operating the lift.

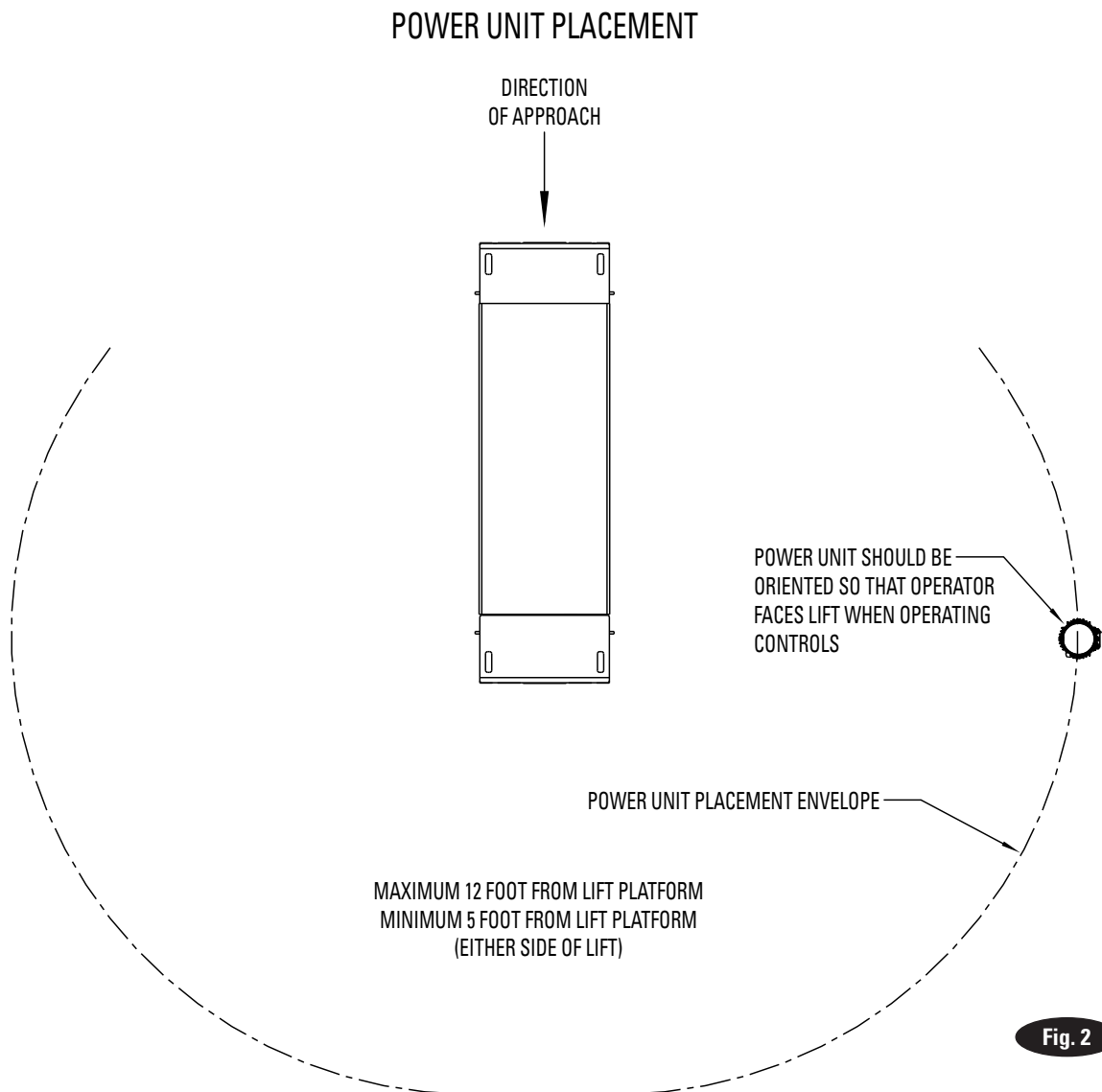

Fig. 2

9. Power Unit and Mounting Post Installation

1. Using the stand as a template mark the location of (4) four floor anchor holes. Using a 1/2" carbide drill bit, drill and install anchors for the mounting post, Fig. 3.

2. Attach (4) four 5/16"-18NC x 1" HHCS to the highest and lowest two holes on the mounting bracket with (4) four 5/16" pushnuts. Attach the power unit using (4) four 5/16"-18NC hex flanged nuts, Fig. 3.

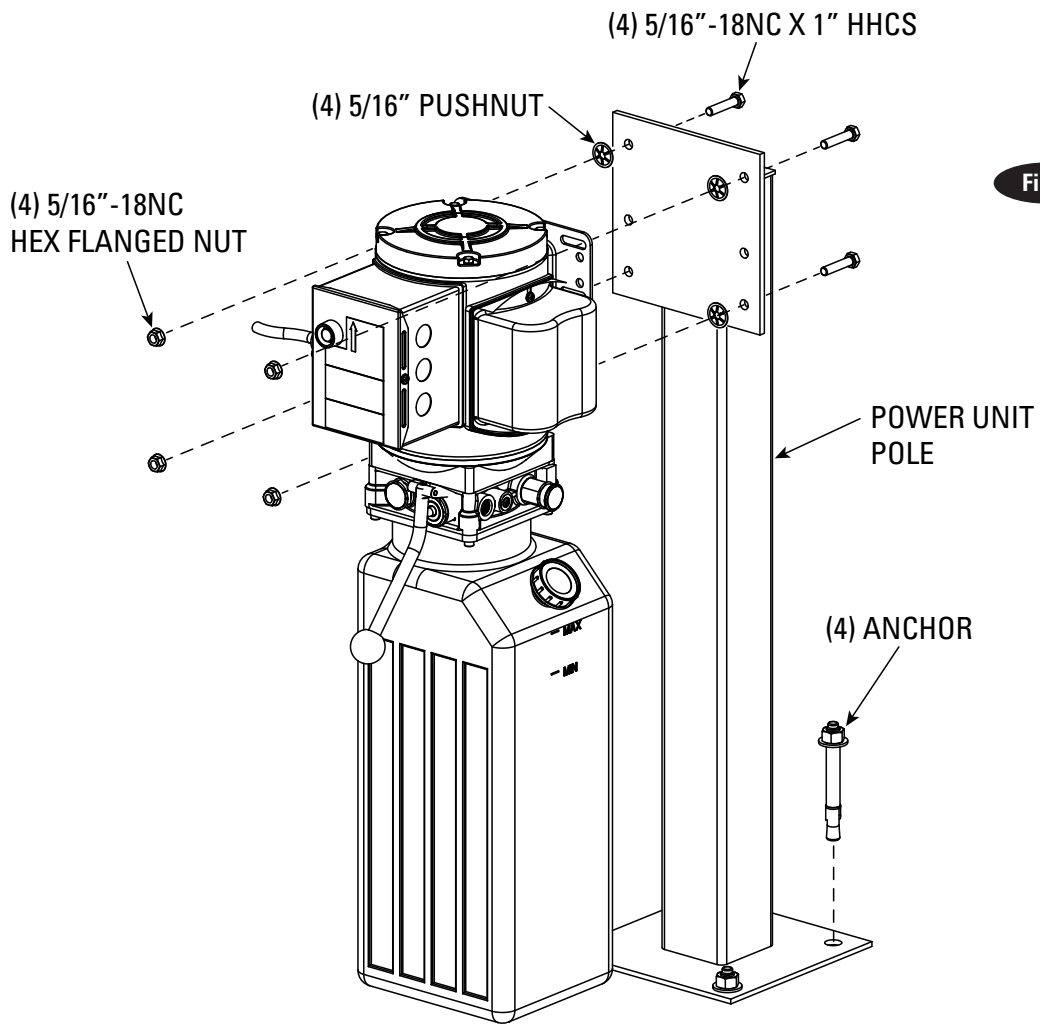

Fig. 3

10. Oil Filling and Bleeding

Use Dexron III ATF, or hydraulic fluid that meets ISO32 specifications. Remove fill breather cap and fill tank full of fluid. Turn power to on and ensure the disconnect switch and emergency stop buttons are in the "ON" position. Proceed with the following steps.

⚠ WARNING Only skilled and authorized personnel should be allowed to perform these operations. Carefully follow all instructions shown below to prevent possible damage to lift or risk of injury to people.

Be sure that the operating area is cleared of people. After positioning the lift as specified and performing electric and hydraulic connections, the lift can be operated by following the specific procedure.

1. Push the "UP" button until platform stops moving.
2. Bleed air from cylinder located underneath the platform using bleed screw, Fig. 4.
3. Lower platform.
4. Repeat process 1 thru 3 several times until no air is released.

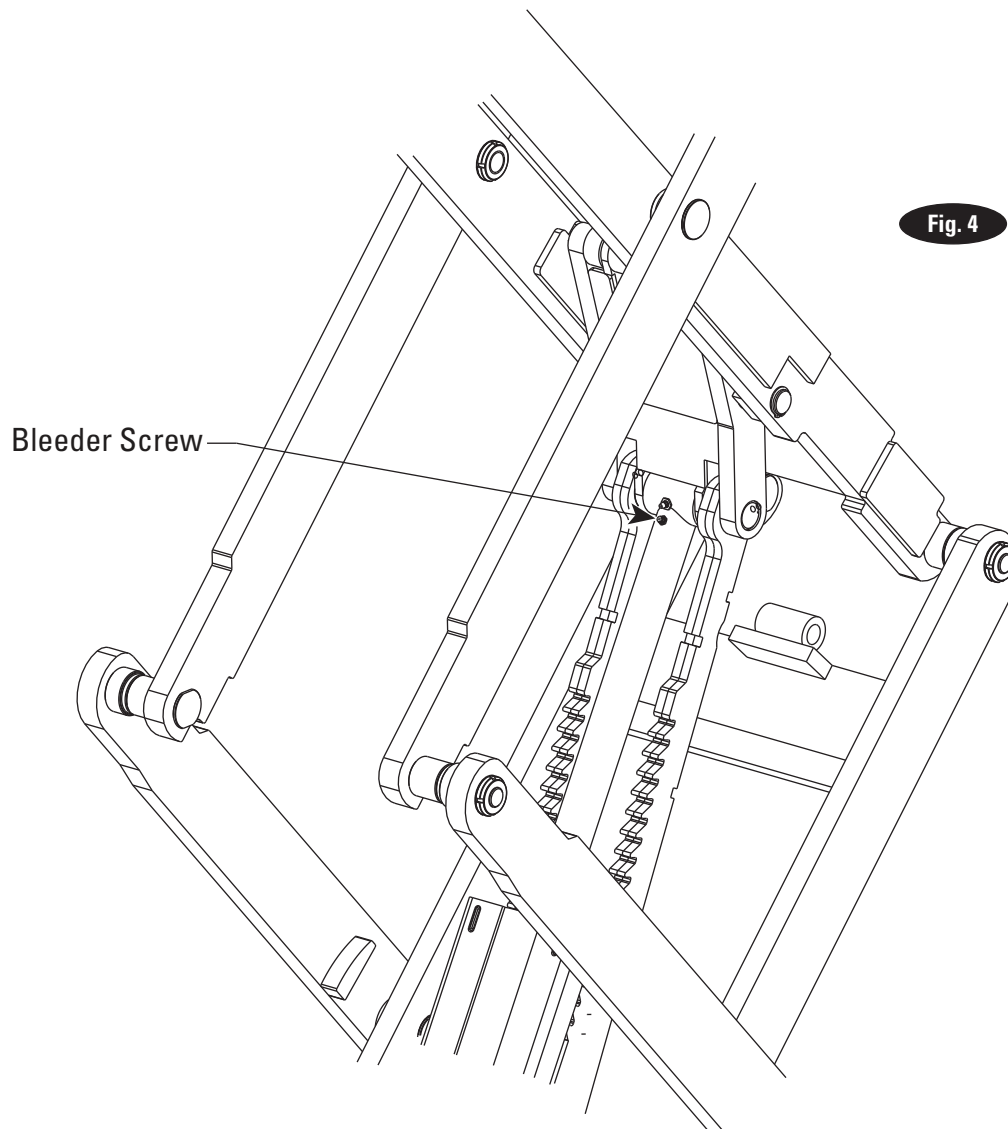

11. Final Positioning of Platform

1. Verify the platform base is square.
2. Verify platform base is level, Fig. 5.

3. Verify platform base is level front to rear, Fig. 6.

4. Verify platform is level, Fig. 7.

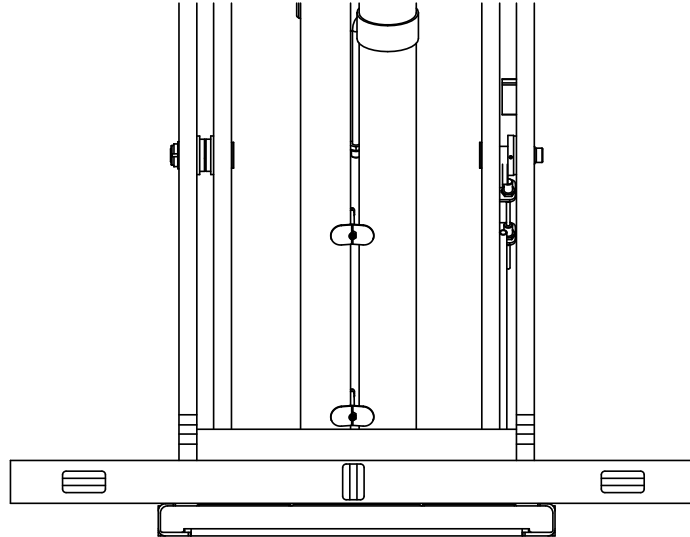

Fig. 5

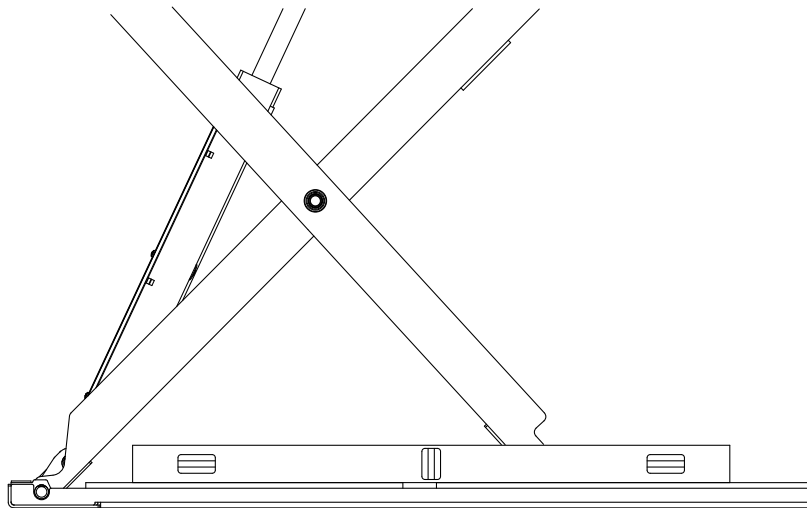

Fig. 6

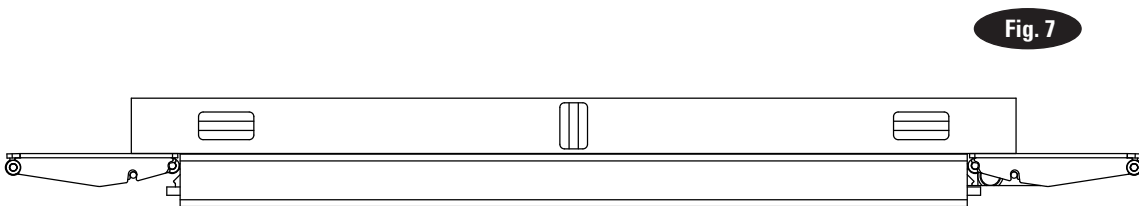

Fig. 7

12. Anchoring

1. Turn the disconnect switch to "ON" and press the "UP" button to raise the platform which provides room under the runway for drilling.
2. Drill and install (4) four lift anchors loosely. Do not tighten.
3. Complete leveling measurements described under item number 11.

4. Shim as necessary, Fig. 8, and tighten anchors.

5. Grout if necessary (see section 13).

6. Re-check for levelness.

⚠ WARNING Do not install this lift without anchoring to required specifications. Failure could result in personal injury or death.

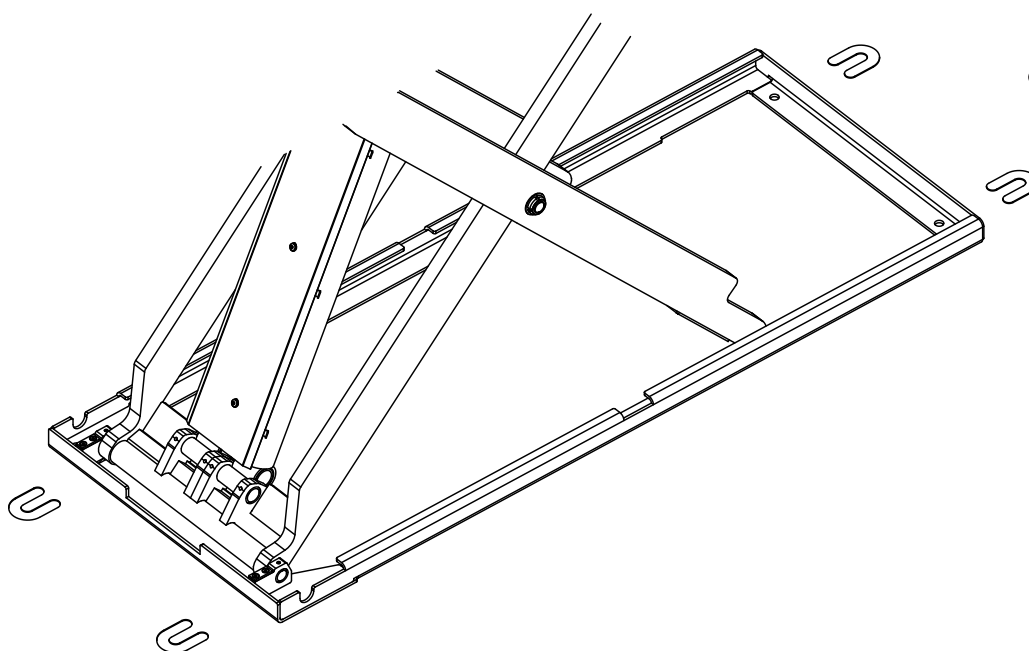

13. Grouting

If lift must be shimmed, Fig. 11, the base must be grouted to provide continuous support. Grout must conform to ASTM C1107 and min. 5,000 psi (34 mpa).

⚠ WARNING If the floor is not level the platform will not be level which could result in unsatisfactory lift performance, property damage, or personal injury.

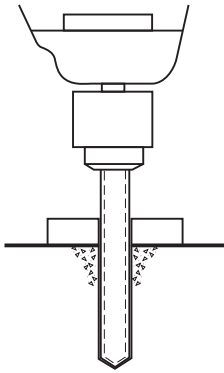

Drill holes using 1/2" carbide tipped masonry drill bit per ANSI B212.15-1994 (R2000)

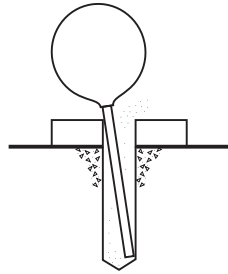

Clean hole.

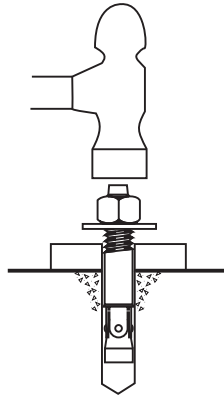

Run nut down just below impact section of bolt. Drive anchor into hole until nut and washer contact base.

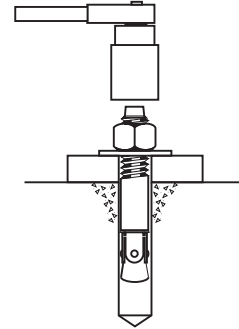

Tighten nut with Torque wrench to 40 ft.-lbs (54N-m)

CONCRETE AND ANCHORING REQUIREMENTS

STANDARD	ANSI/ALI ALCTV IBC 2006, 2009, 2012	SEISMIC
Minimum Floor Thickness	4 INCHES	Varies by location consult with your structural engineer and manufacturer's representative.
Anchor	Hilti Kwik Bolt III 1/2" x 4-1/2" Anchors supplied with the lift.*	
Minimum Concrete Strength	3000 PSI	
Minimum Anchor Embedment	2-1/4 INCHES	
Minimum Distance to Concrete Edge, Crack, Expansion Joint, Abandoned Anchor Hole	3 INCHES	
<p>*The supplied concrete fasteners meet the criteria of the American National Standard "Automotive Lifts - Safety Requirements for Construction, Testing, and Validation" ANSI/ALI ALCTV-2011, and the lift owner is responsible for all charges related to any additional anchoring requirements as specified by local codes.</p> <p>Contact customer service for further information at: 800.445.5438</p>		

14. Adjust Cushion Device

1. To adjust platform height in down position, use cushion screws (49), Fig. 9.

2. Cushion screws extending through cushion weldment (51), Fig. 9, too far will result in platform not lowering completely to the floor. Cushion screws not extending through cushion weldment

far enough will cause the platform to lower to the floor too quickly and the platform to hit the frame too hard. (This will not damage the lift, but will be loud and may be disturbing to technicians.)

3. Once the cushion screws are adjusted properly, tighten lock nuts (48), Fig. 9.

4. Raise and lower lift once more to ensure screws are adjusted correctly.

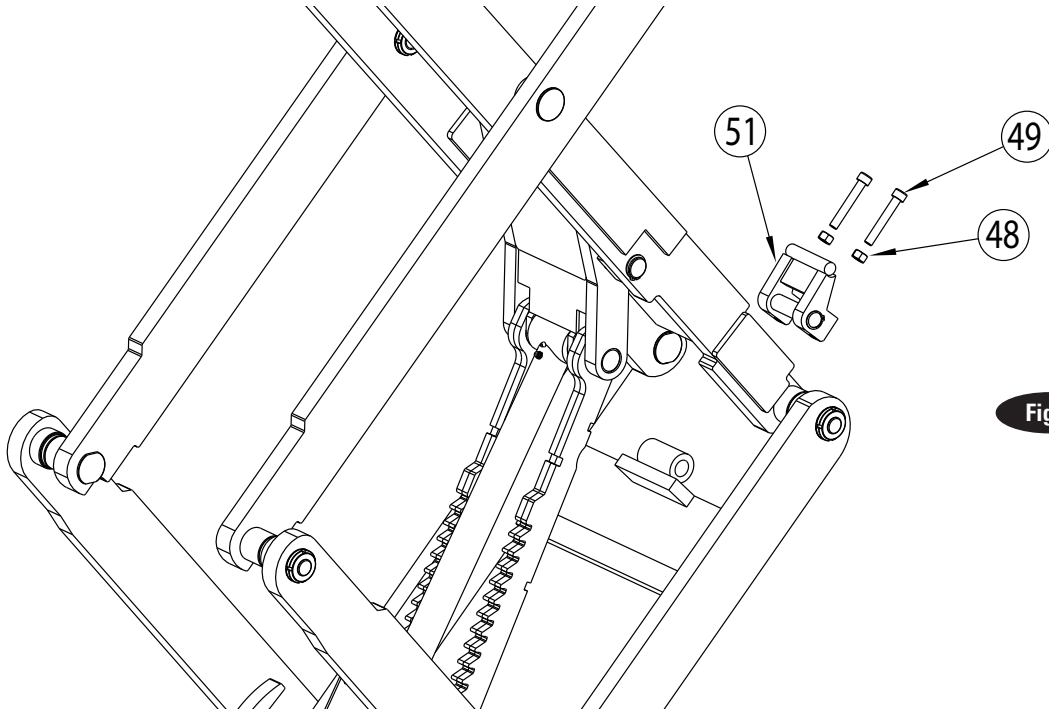

15. Brand Decals

Apply brand decals as shown, Fig. 10.

BRAND DECAL LOCATION
(BOTH SIDES
OUTSIDE SCISSOR)

Fig. 10

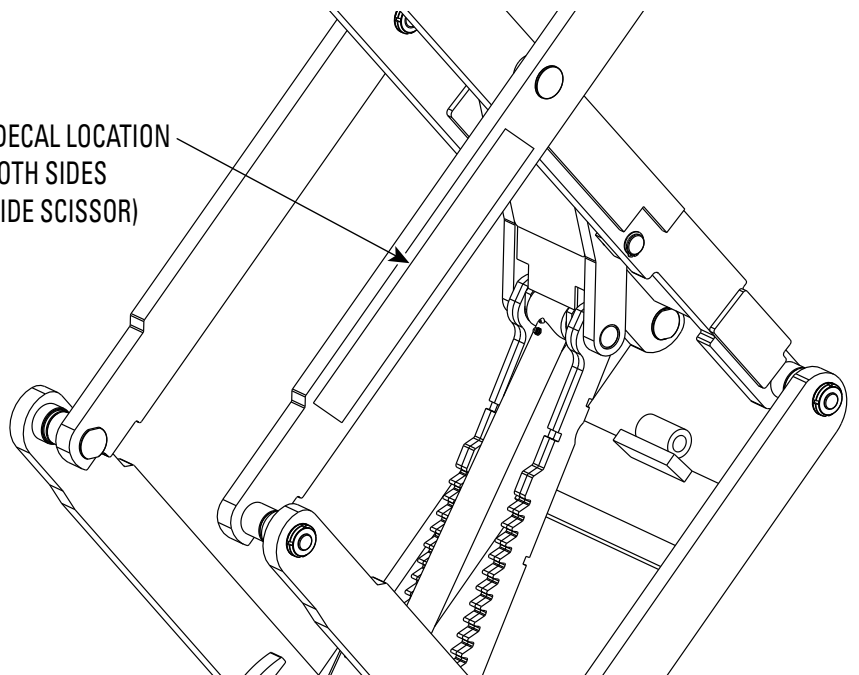

Vehicle Service GroupSM
2700 Lanier Drive
Madison, IN 47250, USA
1-800-640-5438
www.vsgdover.com



© **Vehicle Service GroupSM**
All Rights Reserved. Unless otherwise
indicated, **Vehicle Service GroupSM**,
and all other trademarks are property
of Dover Corporation and its affiliates.